

PITOT-STATIC SYSTEM – PITOT-STATIC TUBES SUPPORT CLAMP

1. PLANNING INFORMATION

- A. EFFECTIVITY PAL 750XL aircraft up to and including XL220.

- B. REASON Production Inspection of installed Pitot-Static plumbing, identified a potential hazard. Insufficient clearance between pitot plumbing and primary support at flame arrestor intersection, could result in chafing of the pitot tube.

- C. DESCRIPTION Install an additional support clamp for Pitot-Static tube support (located next to port flame arrestor), protect plumbing with spiralwrap and fix pitot and static tubes separation to protect pitot-static plumbing from possible chafing.

- D. COMPLIANCE At next 300 hr check.
After complying with this Service Bulletin, refer to Maintenance Manual Chapter 34 for the ongoing Airworthiness Inspections of the Pitot-Static system.

- E. TOOLING No special tools are required.

- F. WEIGHT AND BALANCE No change.

- G. REFERENCE 750XL Maintenance Manual.

- H. HOURS REQUIRED 1 hour.

- I. WARRANTY COVER Normal Warranty conditions apply.

2. ACCOMPLISHMENT INSTRUCTIONS

(Refer to Figure 1)

- 1) Remove the cabin lining at STN 115.34 to access area of the flame arrestor.
- 2) Install pitot-static lines supporting clamps as shown in Figure 1. Use alternative way shown in Figure 2 if pitot-static lines traced between the flame arrestor and fuselage skin.
- 3) Ensure clamps supporting pitot-static lines are located as depicted to prevent low points from forming.
- 4) Protect Pitot-Static plumbing with spiral wrap. Use either existing or additional spiral wrap as required.
- 5) Fix pitot and static tubes separately using cable tie and 8mm-length poli-flo tube as spacer.
- 6) Re-install the cabin lining at STN 115.34.

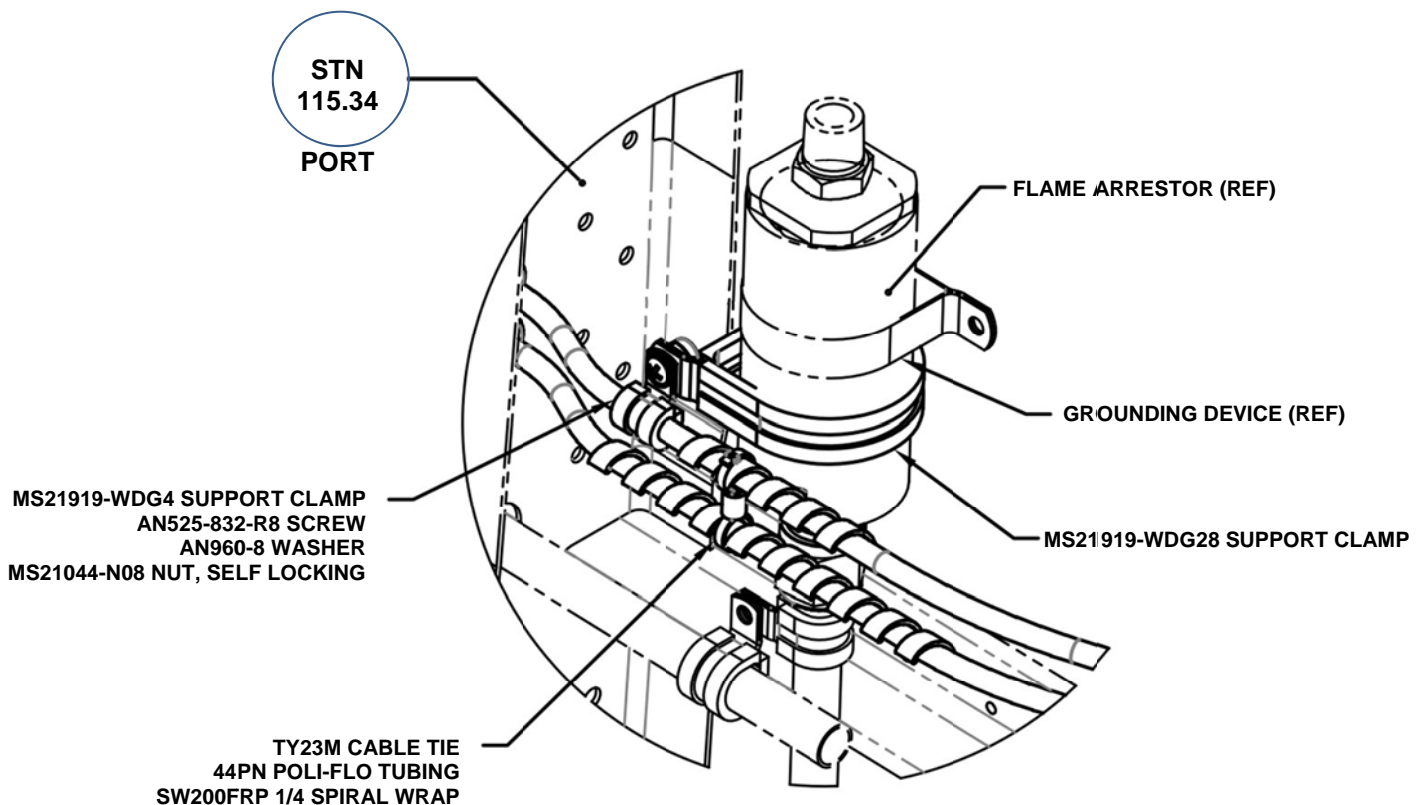

FIGURE 1 PITOT-STATIC SYSTEM – PITOT-STATIC LINES AND FLAME ARRESTOR INTERSECTION

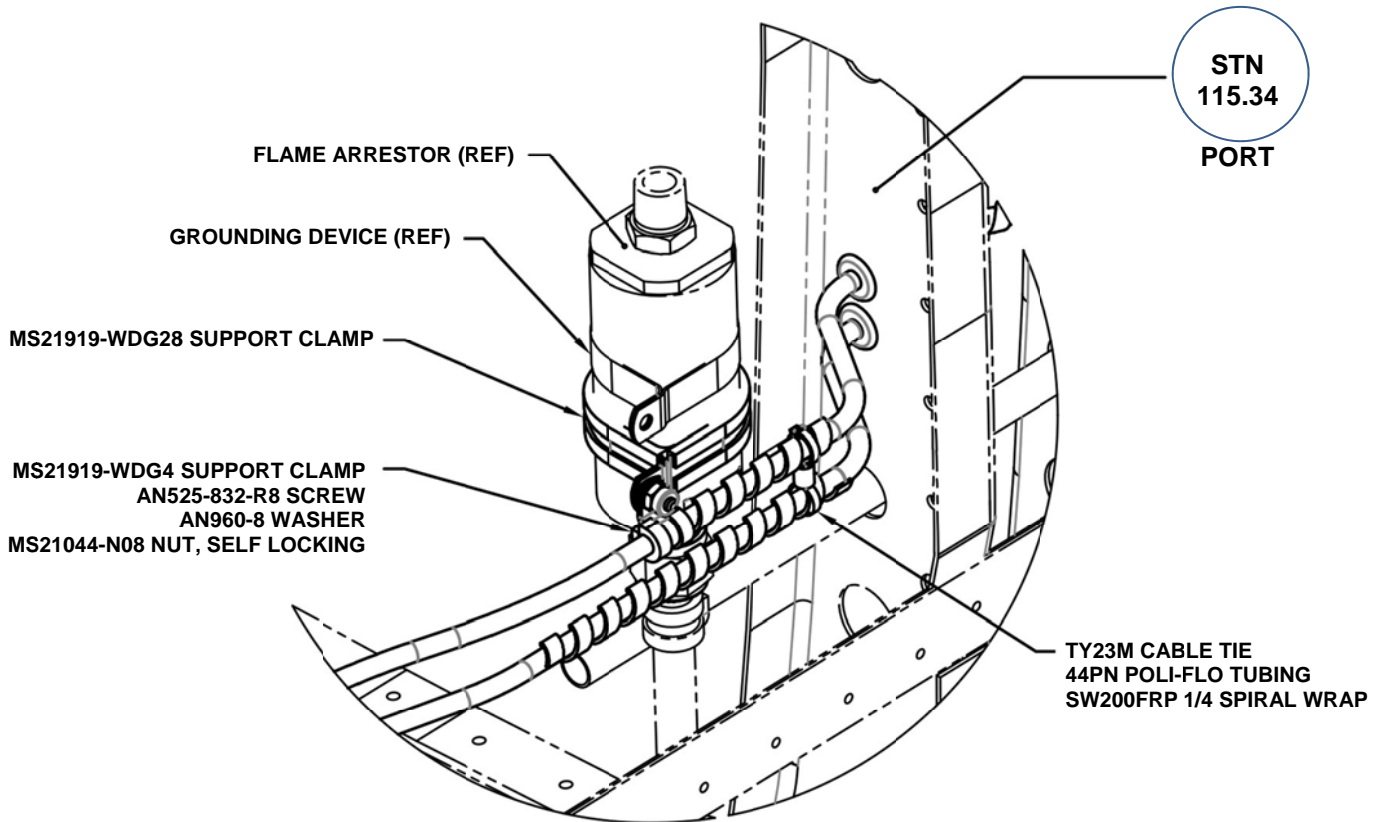

FIGURE 2 PITOT-STATIC SYSTEM – PITOT-STATIC LINES AND FLAME ARRESTOR INTERSECTION (ALTERNATIVE)

3. CERTIFICATION

Record compliance with this Service Bulletin in the aircraft Log Book.

4. MATERIAL REQUIRED:

<u>Description</u>	<u>Part Number</u>	<u>Qty Required</u>
SUPPORT CLAMP	MS21919-WDG28	1
SUPPORT CLAMP	MS21919-WDG4	1
SCREW	AN525-832-R8	1
WASHER	AN960-8	1
NUT, SELF LOCKING	MS21044-N08	1
CABLE TIE	TY23M	1
SPIRAL WRAP	SW200FRP 1/4	200 mm
POLI-FLO TUBING	44PN	8 mm